

INTERNATIONAL
STANDARD

ISO
5211

First edition
2001-02-15

**Industrial valves — Part-turn actuator
attachment**

*Robinetterie industrielle — Raccordement des actionneurs à fraction de
tour*



Reference number
ISO 5211:2001(E)

© ISO 2001

PDF disclaimer

This PDF file may contain embedded typefaces. In accordance with Adobe's licensing policy, this file may be printed or viewed but shall not be edited unless the typefaces which are embedded are licensed to and installed on the computer performing the editing. In downloading this file, parties accept therein the responsibility of not infringing Adobe's licensing policy. The ISO Central Secretariat accepts no liability in this area.

Adobe is a trademark of Adobe Systems Incorporated.

Details of the software products used to create this PDF file can be found in the General Info relative to the file; the PDF-creation parameters were optimized for printing. Every care has been taken to ensure that the file is suitable for use by ISO member bodies. In the unlikely event that a problem relating to it is found, please inform the Central Secretariat at the address given below.

© ISO 2001

All rights reserved. Unless otherwise specified, no part of this publication may be reproduced or utilized in any form or by any means, electronic or mechanical, including photocopying and microfilm, without permission in writing from either ISO at the address below or ISO's member body in the country of the requester.

ISO copyright office
Case postale 56 • CH-1211 Geneva 20
Tel. + 41 22 749 01 11
Fax + 41 22 749 09 47
E-mail copyright@iso.ch
Web www.iso.ch

Printed in Switzerland

Foreword

ISO (the International Organization for Standardization) is a worldwide federation of national standards bodies (ISO member bodies). The work of preparing International Standards is normally carried out through ISO technical committees. Each member body interested in a subject for which a technical committee has been established has the right to be represented on that committee. International organizations, governmental and non-governmental, in liaison with ISO, also take part in the work. ISO collaborates closely with the International Electrotechnical Commission (IEC) on all matters of electrotechnical standardization.

International Standards are drafted in accordance with the rules given in the ISO/IEC Directives, Part 3.

Draft International Standards adopted by the technical committees are circulated to the member bodies for voting. Publication as an International Standard requires approval by at least 75 % of member bodies casting a vote.

Attention is drawn to the possibility that some of the elements of this International Standard may be the subject of patent rights. ISO shall not be held responsible for identifying any or all such patent rights.

International Standard ISO 5211 was prepared by the European Committee for Standardization (CEN) in collaboration with ISO Technical Committee TC 153, *Valves*, Subcommittee SC 2, *Valve actuator attachment*, in accordance with the Agreement on technical cooperation between ISO and CEN (Vienna Agreement).

Throughout the text of this standard, read "...this European Standard..." to mean "...this International Standard...".

This first edition of ISO 5211 cancels and replaces ISO 5211-1:1977, ISO 5211-2:1979 and ISO 5211-3:1982, which have been technically revised.

Contents

	Page
Foreword.....	v
1 Scope	1
2 Normative references	2
3 Terms and definitions.....	2
4 Maximum flange torques.....	2
5 Flange dimensions	3
6 Designation.....	5
7 Dimensions and torques	6
7.1 General.....	6
7.2 Drive by key(s)	6
7.3 Drive by parallel or diagonal square head	9
7.4 Drive by flat head.....	10
8 Position of driven components at interface below part-turn actuator.....	11
8.1 Drive by key(s)	11
8.2 Drive by parallel or diagonal square head	12
8.3 Drive by flat head.....	13
Bibliography	14

Foreword

The text of EN ISO 5211:2001 has been prepared by Technical Committee CEN/TC 69 "Industrial valves", the secretariat of which is held by AFNOR, in collaboration with Technical Committee ISO/TC 153 "Valves".

This European Standard shall be given the status of a national standard, either by publication of an identical text or by endorsement, at the latest by August 2001, and conflicting national standards shall be withdrawn at the latest by August 2001.

This European Standard currently includes actuators with key(s), square and flat drives. Other types of drives may be included in the future.

This European Standard has been prepared under a mandate given to CEN by the European Commission and the European Free Trade Association. This European Standard is considered to be a supporting standard to those application and product standards which in themselves support an essential safety requirement of a New Approach Directive and which make reference to this European Standard.

According to the CEN/CENELEC Internal Regulations, the national standards organizations of the following countries are bound to implement this European Standard: Austria, Belgium, Czech Republic, Denmark, Finland, France, Germany, Greece, Iceland, Ireland, Italy, Luxembourg, Netherlands, Norway, Portugal, Spain, Sweden, Switzerland and the United Kingdom.

1 Scope

This European Standard specifies requirements for the attachment of part-turn actuators, with or without gearboxes, to industrial valves.

The attachment of part-turn actuators to control valves is in accordance with the requirements of this standard only when subject to an agreement between the supplier and the purchaser.

This standard specifies :

- flange dimensions necessary for the attachment of part-turn actuators to industrial valves (see Figure 1a) or to intermediate supports (see Figure 1b) ;
- driving component dimensions of part-turn actuators necessary to attach them to the driven components ;
- reference values for torques for interfaces and for couplings having the dimensions specified in this standard.

The attachment of the intermediate support to the valve is not the subject of this standard.

NOTE 1 In this standard the term "valve" may also be understood to include "valve with an intermediate support" (see Figure 1).

NOTE 2 When the part-turn actuator is a combination of a multi-turn actuator and a gearbox, the multi-turn actuator attachment to the gearbox should be in accordance with EN ISO 5210.

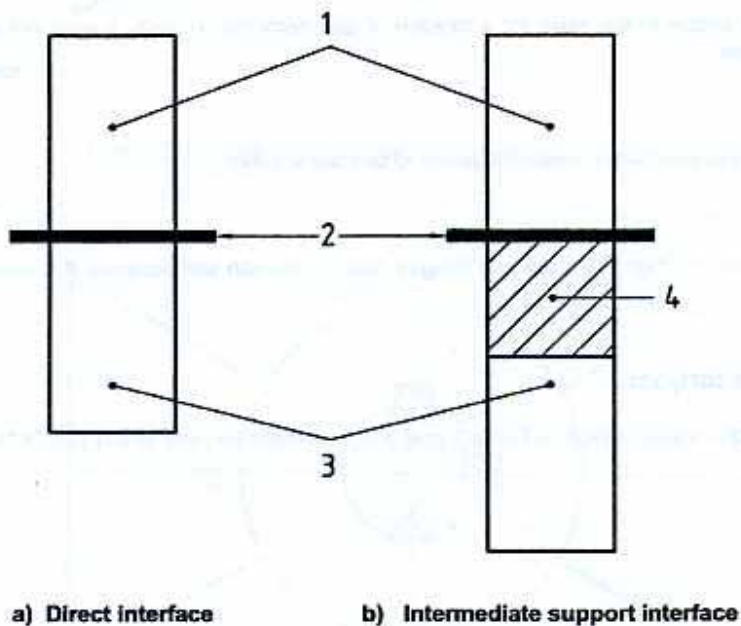

Key

- 1 Part-turn actuator
- 2 Interface
- 3 Valve
- 4 Intermediate support

Figure 1 - Direct and intermediate support interfaces

2 Normative references

This European Standard incorporates by dated or undated reference, provisions from other publications. These normative references are cited at the appropriate places in the text and the publications are listed hereafter. For dated references, subsequent amendments to or revisions of any of these publications apply to this European standard only when incorporate in it by amendments or revision. For undated references, the latest edition of the publication referred to applies (including amendments).

ISO 273, *Fasteners - Clearance holes for bolts and screws.*

ISO/TR 773, *Rectangular or square parallel keys and their corresponding keyways (dimensions in millimetres).*

3 Terms and definitions

For the purposes of this European Standard, the following terms and definitions apply :

3.1

actuator

any power operated device used to operate a valve. The device is designed to operate using motive energy which may be electrical, pneumatic, hydraulic, etc., or a combination of these. Movement is limited by travel, torque or thrust

3.2

part-turn actuator

actuator which transmits torque to the valve for a rotation of one revolution or less. It does not have to be capable of withstanding axial thrust

3.3

gearbox

any mechanism designed to reduce the torque required to operate a valve

3.4

torque

turning moment transmitted through the mounting flanges and connection components. It is expressed in Newton-metres (Nm)

4 Maximum flange torques

The maximum flange torque values listed in Table 1 give the maximum torques which can be transmitted through the mounting flange.

Table 1 - Maximum flange torque values

Flange type	Maximum flange torque Nm
F03	32
F04	63
F05	125
F07	250
F10	500
F12	1 000
F14	2 000
F16	4 000
F25	8 000
F30	16 000
F35	32 000
F40	63 000
F48	125 000
F60	250 000

The values specified in Table 1 have been defined on the basis of bolts in tension only at a stress of 290 MPa¹ and a coefficient of friction of 0,2 between the mounting interface. All variations in these defined parameters lead to variations of the transmittable torque values.

The selection of flange types for a particular application should take into account the additional torques that may be generated because of inertia or other factors.

5 Flange dimensions

Flanges for part-turn actuator attachments shall comply with the dimensions shown in Figure 2 and given in Table 2. The method of attachment shall be by means of studs, screws or through bolting. When through bolting is used, the diameter of the clearance holes shall permit the use of bolts of a size given by the corresponding dimension d_4 in Table 2. Holes for the studs, screws or bolts shall be equi-spaced and positioned off-centre (see Figure 3 and Table 3), and shall conform to the requirements of ISO 273.

The flange on the valve shall have a recess corresponding to the diameter d_2 ; a spigot on the part-turn actuator is optional.

The minimum values for dimension h_2 apply to flanges having material of proof stress $R_{p0,2} \geq 200$ MPa.

Dimension d_1 has been calculated to provide sufficient seating for nuts and bolt heads. Such seating is defined as a radius from the bolt hole centre with the dimension $(d_1 - d_3) / 2$, and is a minimum. The flange shape and the design of the mounting surface of the valve and part-turn actuator outside these areas of seating is left to the choice of the manufacturer.

¹ 1MPa = 1N/mm²

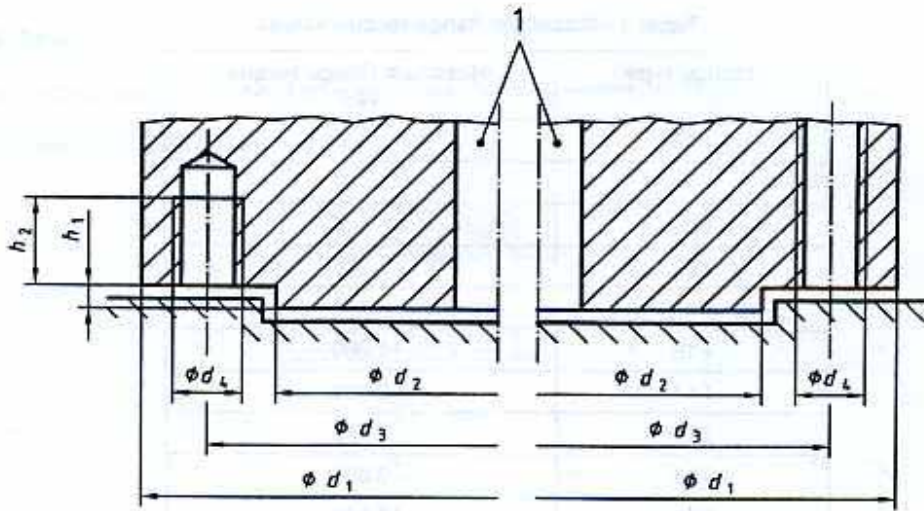

Key

- 1 Part-turn actuator

Figure 2 - Flange dimensions

Table 2 - Flange dimensions

Dimensions in millimetres

Flange type	d_1	d_2 f8	d_3	d_4	h_1 max.	h_2 min.	Number of screws, studs or bolts
F03	46	25	36	M5	3	8	4
F04	54	30	42	M5	3	8	4
F05	65	35	50	M6	3	9	4
F07	90	55	70	M8	3	12	4
F10	125	70	102	M10	3	15	4
F12	150	85	125	M12	3	18	4
F14	175	100	140	M16	4	24	4
F16	210	130	165	M20	5	30	4
F25	300	200	254	M16	5	24	8
F30	350	230	298	M20	5	30	8
F35	415	260	356	M30	5	45	8
F40	475	300	406	M36	8	54	8
F48	560	370	483	M36	8	54	12
F60	686	470	603	M36	8	54	20

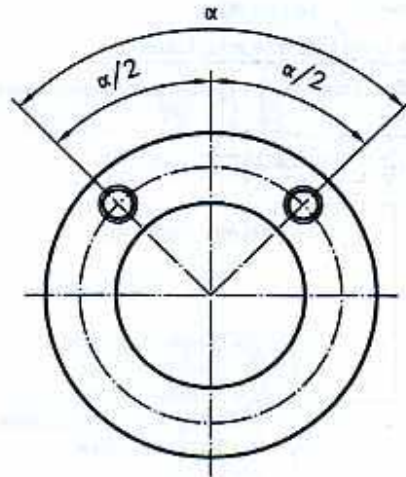

Figure 3 - Position of holes

Table 3 - Position of holes

Flange type	$\alpha / 2$
F03 to F16	45 °
F25 to F40	22,5 °
F48	15 °
F60	9 °

6 Designation

Part-turn valve actuator attachments shall be designated as follows :

- flange designation :
 - flange type as per Table 1 ;
 - a capital letter for spigot identification :
 - Y with spigot ;
 - N without spigot ;
- drive designation :
 - an additional capital letter for drive identification :
 - V for single key drive ;
 - W for two key drive ;
 - L for parallel square drive ;
 - D for diagonal square drive ;
 - H for flat head drive ;

- the actual dimensions of the drive (in millimetres) :
 - dimension d_f for key drives (see Figure 4 and Table 4) ;
 - dimension s for square or flat drives (see Figures 5 or 6 and Table 5 or Figure 7 and Table 6).

EXAMPLE

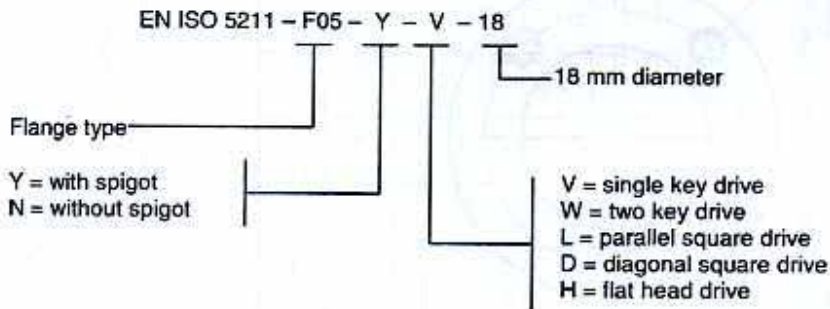

EN ISO 5211 - F05 - Y - V - 18, identifies a part-turn valve actuator attachment in accordance with this standard, with F05 flange type, spigot and single key drive with 18 mm diameter.

NOTE The designation is not a marking requirement.

7 Dimensions and torques

7.1 General

To ensure that no interference can occur between the driving component and the driven component, the length of the driven component above the interface shall be limited so that there is a clearance between both parts.

7.2 Drive by key(s)

Dimensions of drive components for key drive shall meet the requirements of Figure 4 and Table 4.

The values of d_f , h_4 and l_5 in Table 4 are based on single key design up to 98 mm shaft diameter.

Where more than one key is required to transmit the torque, the dimensions in Table 4 shall still apply.

The key dimensions shall comply with those given in ISO/TR 773.

The keyway(s) in the driving component shall correspond to the position of the key(s) supplied on the driven component as specified in 8.1, Figures 8 or 9.

The key(s) shall be secured in position by suitable means.

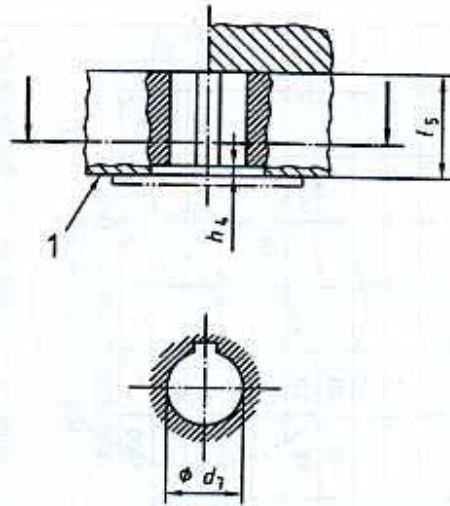

- Key
- 1 Interface

Figure 4 - Drive by key(s)

Table 4 - Dimensions and torques for drive by key(s)

Dimensions in millimetres

Flange e type	Max. flange torque Nm	r_h max. ¹	k min.	d , H9 ^a																						
				12	14	16 ^c	18	22	28	36	42	48	50	60	60 ^b	72	80	80	98 ^b	100	120	160	180	220	280	
F05	125	3,0	30																							
F07	250	3,0	35	-	14	16	18	22 ^c	28	-	-	-	-	-	-	-	-	-	-	-	-	-	-	-	-	-
F10	500	3,0	45	-	-	18	22	28 ^c	36	42	-	-	-	-	-	-	-	-	-	-	-	-	-	-	-	-
F12	1000	3,0	55	-	-	-	22	28	36 ^c	42	48	50	-	-	-	-	-	-	-	-	-	-	-	-	-	-
F14	2000	5,0	65	-	-	-	-	28	36	42	48 ^b	50	-	-	-	-	-	-	-	-	-	-	-	-	-	-
F16	4000	5,0	80	-	-	-	-	-	-	42	48	50	60 ^b	72	80	-	-	-	-	-	-	-	-	-	-	-
F25	8000	5,0	110	-	-	-	-	-	-	-	48	50	60	72 ^b	80	98	100	-	-	-	-	-	-	-	-	-
F30	16000	5,0	130	-	-	-	-	-	-	-	-	-	60	72	80	98 ^b	100	120	-	-	-	-	-	-	-	-
F35	32000	5,0	180	-	-	-	-	-	-	-	-	-	-	-	-	-	-	-	-	-	160	-	-	-	-	
F40	63000	8,0	200	-	-	-	-	-	-	-	-	-	-	-	-	-	-	-	-	-	-	-	180	-	-	
F48	125000	8,0	250	-	-	-	-	-	-	-	-	-	-	-	-	-	-	-	-	-	-	-	-	220	-	
F60	250000	8,0	310	-	-	-	-	-	-	-	-	-	-	-	-	-	-	-	-	-	-	-	-	-	280	
Max. transmissible torque Nm^d				32	63	125	250	500	1000	1500	2000	3000	4000	8000	12000	16000	*	*	*	*	*	*	*	*	*	*

^a For flange types F05 to F30 other dimensions of d between those indicated are permitted for a maximum of 5 years after the publication of this standard.

^b For flange types above F30, the d values given is the maximum and any value up to this maximum is permitted, subject to considerations in d below.

^c Indicates the preferred dimension.

^d For flange types F05 to F30, these are the corresponding torques which can be transmitted by the driving components having the d dimensions. They are based on a max. allowable torsional stress of 280 MPa for the driven component, a max. compressive stress on the key of 350 MPa and an effective length of key engagement equal to $(5 \cdot r_h)$.

* The maximum transmissible torques shall be determined by calculation.

¹ $r_{h, min} = 0,5$ mm.

7.3 Drive by parallel or diagonal square head

Dimensions of drive components for square heads shall meet the requirements of Figures 5 or 6 and Table 5. The choice of d_6 and d_9 depends on the manufacturing process.

The square drive positions shall be as specified in 8.2, Figures 10 or 11.

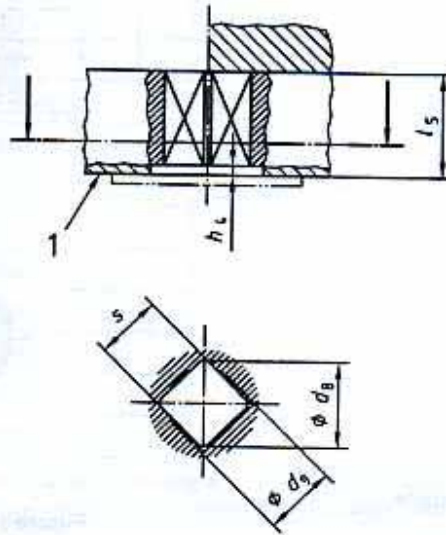
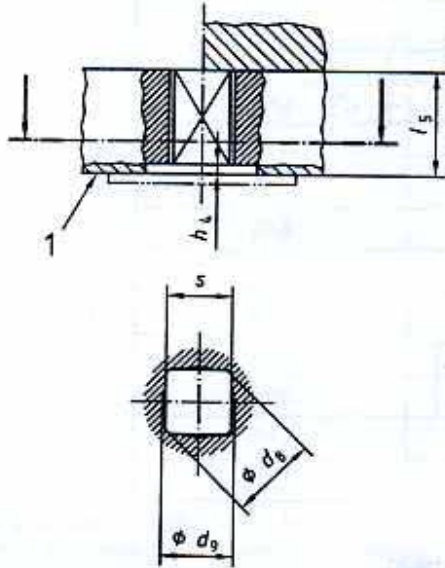

Key

1 Interface

Figure 5 - Drive by parallel square head

Figure 6 - Drive by diagonal square head

Table 5 - Dimensions and torques for drive by parallel or diagonal square head

Dimensions in millimetres

Flange type	Max. flange torque Nm	h_4 max. ^a	s H11												
			9	11 ^b	14 ^b	17 ^b	19	22 ^b	27 ^b	36 ^b	46 ^b	55 ^b	75 ^b		
F03	32	1,5	9	-	-	-	-	-	-	-	-	-	-	-	
F04	63	1,5	9	11 ^b	-	-	-	-	-	-	-	-	-	-	
F05	125	3,0	9	11	14 ^b	-	-	-	-	-	-	-	-	-	
F07	250	3,0	-	11	14	17 ^b	-	-	-	-	-	-	-	-	
F10	500	3,0	-	-	14	17	19	22 ^b	-	-	-	-	-	-	
F12	1000	3,0	-	-	-	17	19	22	27 ^b	-	-	-	-	-	
F14	2000	5,0	-	-	-	-	-	22	27	36 ^b	-	-	-	-	
F16	4000	5,0	-	-	-	-	-	-	27	36	46 ^b	-	-	-	
F25	8000	5,0	-	-	-	-	-	-	-	36	46	55 ^b	-	-	
F30	16000	5,0	-	-	-	-	-	-	-	-	46	55	75 ^b	-	
$\varnothing d_9$ min.			12,1	14,1	18,1	22,2	25,2	28,2	36,2	48,2	60,2	72,2	98,2	-	-
$\varnothing d_9$ max.			9,5	11,6	14,7	17,9	20	23,1	28,4	38	48,5	57,9	79,1	-	-
l_5 min			10	12	16	19	21	24	29	38	48	57	77	-	-
Max. transmissible torque Nm ^c			32	63	125	250	350	500	1000	2000	4000	8000	16000	-	-

^a h_4 min. = 0,5 mm.

^b Indicates the preferred dimension.

^c Maximum transmissible torques are based on a maximum allowable torsional stress of 280 MPa for the driven component.

7.4 Drive by flat head

Dimensions of drive components for flat head drive shall meet the requirements of Figure 7 and Table 6.

The flat head drive position shall be as specified in 8.3, Figure 12.

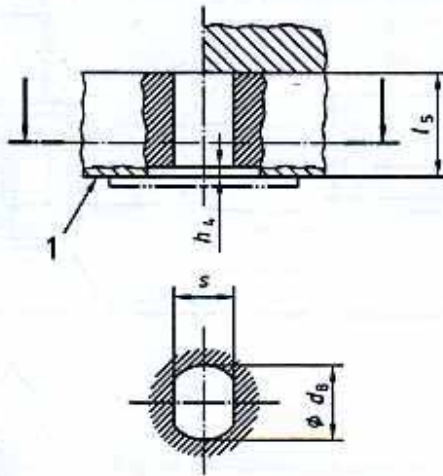

Key

- 1 Interface

Figure 7 - Drive by flat head

Table 6 - Dimensions and torques for drive by flat head

Dimensions in millimetres

Flange type	Max. flange torque Nm	h_4 max. ^a	s H11										
			9	11 ^b	14 ^b	17 ^b	19	22 ^b	27 ^b	36 ^b	46 ^b	55 ^b	75 ^b
F03	32	1,5	9	-	-	-	-	-	-	-	-	-	-
F04	63	1,5	9	11 ^b	-	-	-	-	-	-	-	-	-
F05	125	3,0	9	11	14 ^b	-	-	-	-	-	-	-	-
F07	250	3,0	-	11	14	17 ^b	-	-	-	-	-	-	-
F10	500	3,0	-	-	14	17	19	22 ^b	-	-	-	-	-
F12	1000	3,0	-	-	-	17	19	22	27 ^b	-	-	-	-
F14	2000	5,0	-	-	-	-	-	22	27	36 ^b	-	-	-
F16	4000	5,0	-	-	-	-	-	27	36	46 ^b	-	-	-
F25	8000	5,0	-	-	-	-	-	-	36	46	55 ^b	-	-
F30	16000	5,0	-	-	-	-	-	-	-	46	55	75 ^b	-
ϕd_s min.			12,1	14,1	18,1	22,2	25,2	28,2	36,2	48,2	60,2	72,2	98,2
l_5 min.			16	19	25	30	34	39	48	64	82	99	135
Max. transmissible torque Nm ^c			32	63	125	250	350	500	1000	2000	4000	8000	16000

^a h_4 min. = 0,5 mm

^b Indicates the preferred dimension

^c Maximum transmissible torques are based on a maximum allowable torsional stress of 280 MPa for the driven component

8 Position of driven components at interface below part-turn actuator

8.1 Drive by key(s)

One or two keys may be used. With the valve closed the key(s) shall be located as shown in Figures 8 or 9. If more than two keys are required, their position shall be subject to an agreement between the supplier and the purchaser.

NOTE The standard closing direction is clockwise, as viewed from above the interface.

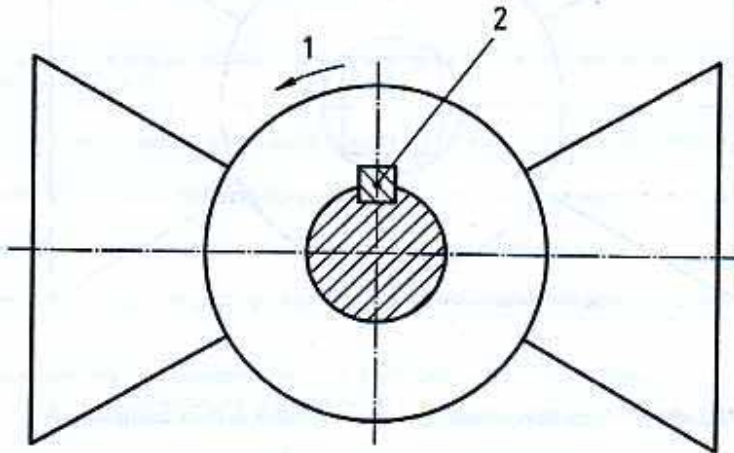

Key

- 1 Opening direction
- 2 Primary key

Figure 8 – Position of primary key on the driven component

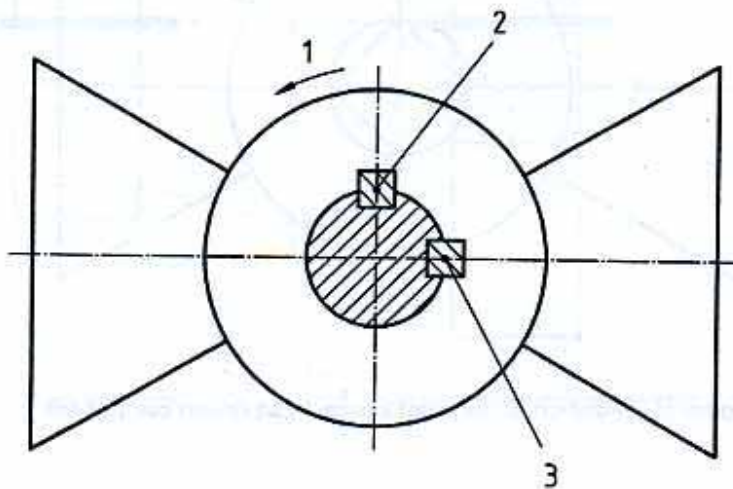

Key

- 1 Opening direction
- 2 Primary key
- 3 Secondary key

Figure 9 – Positions of primary and secondary keys on the driven component

8.2 Drive by parallel or diagonal square head

With the valve closed, the flat sides of the square head drive component shall be located as shown in Figures 10 or 11.

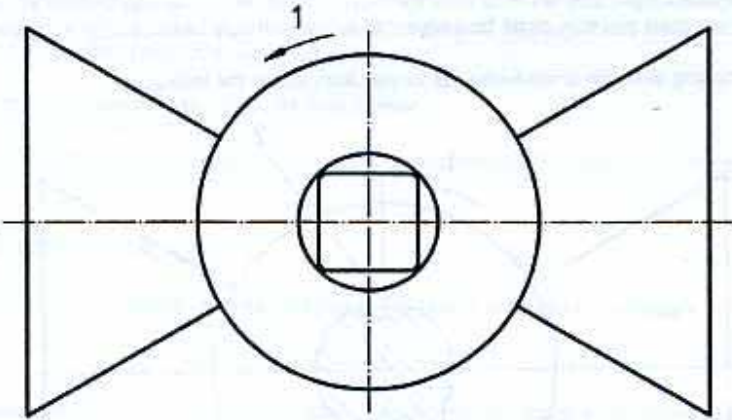

Key
1 Opening direction

Figure 10 – Position of parallel square head driven component

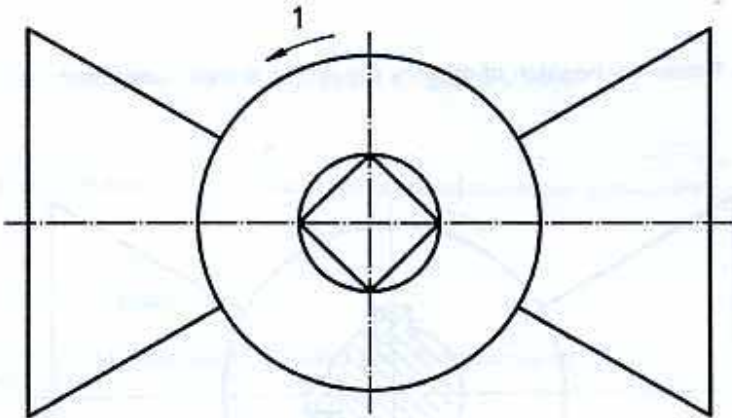

Key
1 Opening direction

Figure 11 – Position of diagonal square head driven component

8.3 Drive by flat head

With the valve closed, the flat sides of the flat head drive component shall be located as shown in Figure 12.

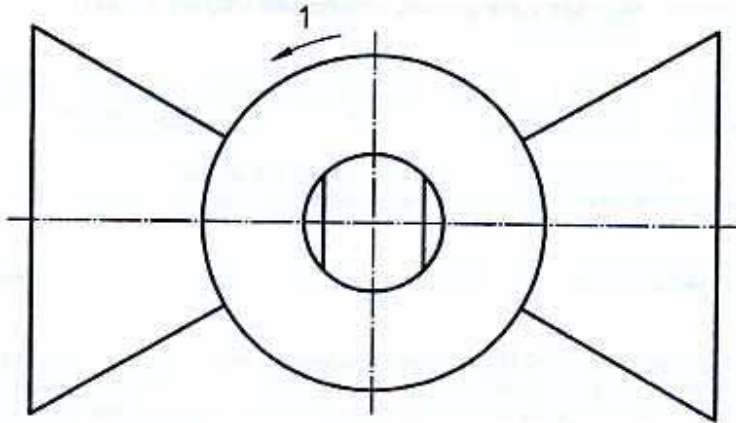

Key

- 1 Opening direction

Figure 12 - Position of flat head driven component

Bibliography

EN ISO 5210, *Industrial valves - Multi-turn valve actuator attachments (ISO 5210 :1991)*.

