

AGA SIZE: 1/2" ~ 2"

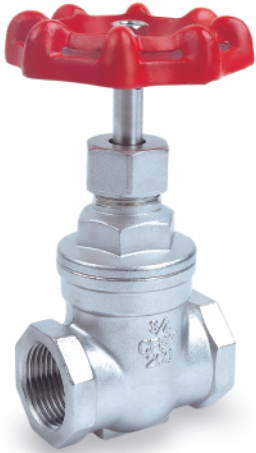

FEATURES:

- *Pipe thread in accordance with ANSI B2.1, BS 21:1973, DIN 259/2999, ISO 228
- *Pressure rating: 200 PSI
- *Investment casting body and bonnet
- *Handwheel

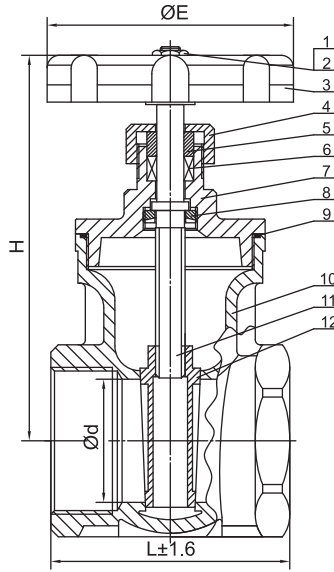
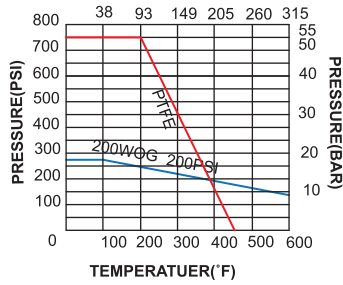

MATERIALS LIST

NO.	NAME	QTY	MATERIALS	
			316	304
1	Nut	1	316	304
2	Name plate	1	AL	AL
3	HandleWheel	1	AL	AL
4	Gland Nut	1	CF8M	CF8
5	Ring	1	316	304
6	Stem Packing	2	PTFE	PTFE
7	Bonnet	1	CF8M	CF8
8	Stem Holder	1	316	304
9	Gasket	1	PTFE	PTFE
10	Body	1	CF8M	CF8
11	Stem	1	316	304
12	Disc	1	CF8M	CF8

DIMENSIONS

Size Item	UNIT:mm			
	d	L	H	E
1/2"	15	56	95	70
3/4"	20	61	104	70
1"	25	66	115	80
1-1/4"	32	76	131	80
1-1/2"	38	86	144.5	90
2"	50	96	162.5	100

AGL SIZE: 1/2" ~ 3"



FEATURES:

- *Pipe thread in accordance with ANSI B2.1, BS 21:1973, DIN 259/2999, ISO 228
- *Pressure rating: 200 PSI
- *Investment casting body and cap
- *Handwheel

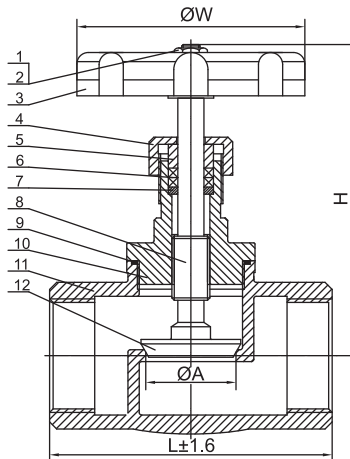
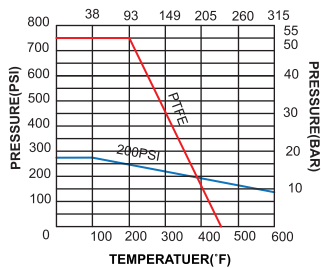

MATERIALS LIST

NO.	NAME	QTY	MATERIALS	
			316	304
1	Nut	1	316	304
2	Stem Washer	1	316	304
3	Handle Wheel	1	AL	AL
4	Gland Ring	1	CF8M	CF8
5	Ring	1	316	304
6	Stem Packing	2	PTFE	PTFE
7	Washer	1	316	304
8	Stem	1	316	304
9	Gasket	1	PTFE	PTFE
10	Cap	1	CF8M	CF8
11	Body	1	CF8M	CF8
12	Petal	1	316	304

DIMENSIONS

SIZE	UNIT:mm				
	A	L	H	W	Kg
1/2"	15	61	85	70	0.35
3/4"	20	73.5	95	70	0.48
1"	25	83.5	104	80	0.68
1-1/4"	32	93.5	113	90	1.02
1-1/2"	38	103	125.5	90	1.49
2"	50	123	142	100	2.22
2-1/2"	65	152	146	120	---
3"	76	179	180	140	---

ACK SIZE: 1/2" ~ 4"



FEATURES:

- *Pipe thread in accordance with ANSI B2.1, BS 21:1973, DIN 259/2999, ISO 228
- *Pressure rating: 200 PSI
- *Investment casting body and cap

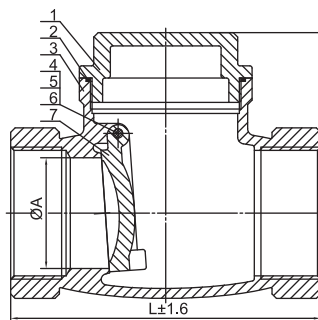
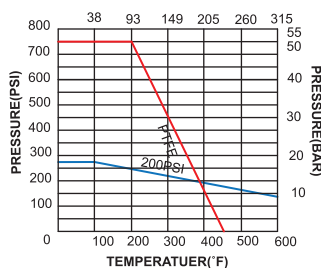

MATERIALS LIST

NO.	PART NAME	QTY	MATERIALS	
			316	304
1	Cap	1	CF8M	CF8
2	Gasket	1	PTFE	PTFE
3	Body	1	CF8M	CF8
4	Hanger Pin	1	316	304
5	Bolt	1	B8	B8
6	Gasket	1	PTFE	PTFE
7	Disc	1	CF8M	CF8

DIMENSIONS

SIZE	ITEM	UNIT:mm			KGS
		A	L	H	
1/2"		15	64.5	42.5	0.28
3/4"		20	79.5	52	0.445
1"		25	89.5	61.5	0.64
1-1/4"		32	104	63	0.895
1-1/2"		40	119	71.5	1.355
2"		50	138.5	75.5	1.885
2-1/2"		65	185	93	3.45
3"		80	200	104	4.9
4"		100	240	139	8.87