

V2N SIZE: 1/4" ~ 4"



STAINLESS STEEL
 AISI-316 (DIN 1.4408) (ASTM-A351-CF8M)
 AISI-304 (DIN 1.4308) (ASTM-A351-CF8)
CARBON STEEL
 S-45C (DIN 1.0619) (ASTM-A216-WCB)

FEATURES:

- *Pipe thread in accordance with ANSI B2.1, BS 21:1973, DIN 259/2999, ISO 228
- *Pressure rating: 1000 PSI (63 BAR)
- *Investment casting body and cap
- *Blow-out proof stem
- *With mounting pad
- *Lug body

OPTION:

- *Locking device
- *Drilling and tapped mounting pad
- *Face-to-face for A2E length

MATERIALS LIST

ITEM	PARTS	QTY	MATERIALS		
			316	304	WCB
1	BODY	1	ASTM-A351-CF8M	ASTM-A351-CF8	ASTM-A216-WCB
2	CAP	1	ASTM-A351-CF8M	ASTM-A351-CF8	ASTM-A216-WCB
3	BALL	1	ASTM-A351-CF8M	ASTM-A351-CF8	ASTM-A351-CF8
4	BALL SEAT	2	PTFE	PTFE	PTFE
5	JOINT GASKET	1	PTFE	PTFE	PTFE
6	STEM	1	AISI 316	AISI 304	AISI 304
7	THRUST WASHER	1	PTFE	PTFE	PTFE
8	STEM PACKING	2	PTFE	PTFE	PTFE
9	GLAND NUT	1	AISI 304	AISI 304	AISI 304
10	HANDLE	1	AISI 430	AISI 430	AISI 430
11	SPRING WASHER	1	AISI 304	AISI 304	AISI 304
12	STEM NUT	1	AISI 304	AISI 304	AISI 304
13	PLASTIC COVER	1	P.V.C	P.V.C	P.V.C
14	LOCK DEVICE	1	AISI 430	AISI 430	AISI 430

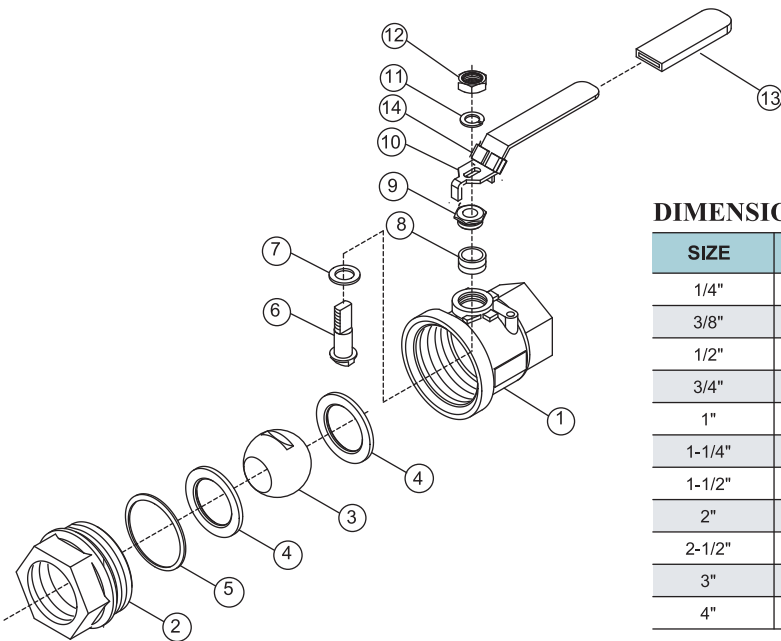
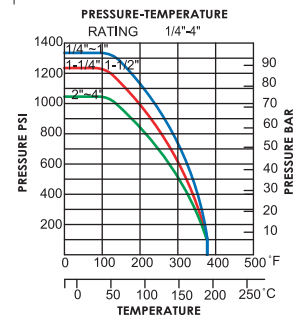
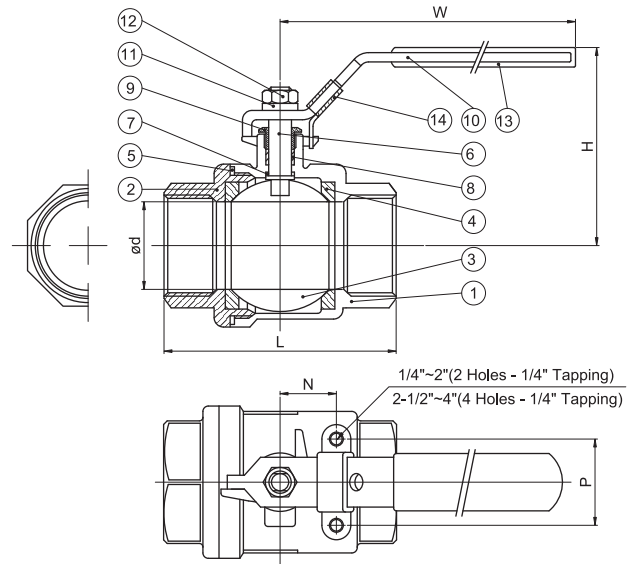

DIMENSIONS

SIZE	Ød	L	H	W	N	P	UNIT:mm		
							CV FACTOR	TORQUE kgf-cm	KGS
1/4"	11.6	51	50	98	12.5	28.5	6.6	40	0.25
3/8"	12.7	50	50	98	12.5	28.5	7.9	40	0.25
1/2"	15	56	52	98	12.5	28.5	11.2	54	0.32
3/4"	20	63.5	62	98	21	35	21	78	0.51
1"	25	78	75	143	22.6	35	35	106	0.86
1-1/4"	32	90	80	143	23.5	38.1	57	150	1.44
1-1/2"	38	104	100	173	23.5	38.1	80	200	2.03
2"	50	124.5	111	173	23.5	38.1	150	280	3.03
2-1/2"	65	160.5	136	223	35	56	265	480	6.0
3"	80	187	148	223	35	56	415	750	9.5
4"	100	240	173	308	50	63	780	1100	19